

EVERY CHILD IS AN ARTIST

A HANDBOOK – ELEMENTARY & INTERMEDIATE DRAWING GRADE EXAMINATION

Restructured Curriculum 2015

JAY SALIAN

AN ARTIST, ANIMATOR & MENTOR



<http://jaysalian.wikifoundry.com/>

Elementary Grade Drawing Examination

OBJECT DRAWING

(First Paper - First Day)

Exam Timings 10.30 am to 1.00 pm (2^{1/2} Hours)

1. Syllabus:

(1) To draw a group of man-made and natural objects placed in the front. (2) To draw the objects in appropriate sizes in proportion to the given paper size. (3) To skillfully colour the objects as they appear, with exact shade and light and using appropriate colours. (4) Any colour medium or colouring techniques of your choice may be used for e.g. stippling, textures, collage, etc.

2. Suggested media:

(1) Coloured pencils (2) Wax crayons (3) Water colours (Transparent/Opaque) (4) Oil pastels (5) Coloured inks (6) Natural colours. These media may be used either singly or in combination.

3. Objects: (1) Bucket, dustbin, tub, drum, water bottle. (2) Big clay pots, pitchers in attractive shapes, China clay utensils. (3) Glass containers, glass, and plate. (4) Basket, mug, bowl, tray, big and small water vessels, broom. (5) Large sized square boxes, wooden blocks. (6) Natural objects such as big-sized flowers, brinjal, tomato, pumpkin, capsicum, cabbage, cucumber, coconut, banana, apple, orange, papaya, sweet lime, etc.

Materials:

1. A3 portable drawing pad/board.



2. HB/2B pencil with sharpener & eraser.



3. Cotton rag to clean brush & No spill pot/water container.



4. 24 shades Water colour cakes.



5. 15 shades Oil pastel colours.



6. No.-2,4,6 Round & 1inch flat fine golden taklon hair brush.



Method:

1. Draw freehand 1.5cm border on the drawing paper provided.



2. Compose the given object shapes on the paper.

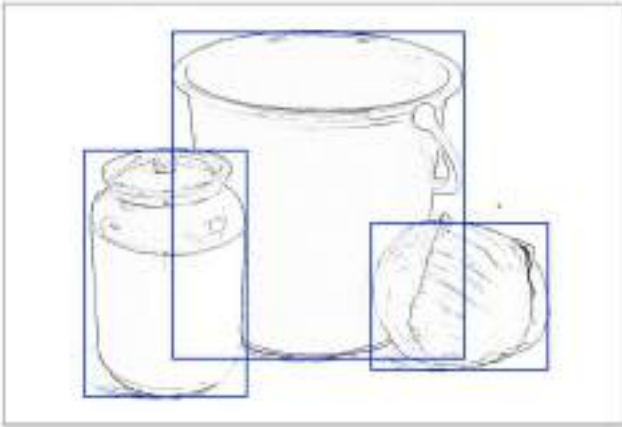

3. Do detailed drawing.



4. Apply water colour on object drawings. Let it dry.



5. Use oil pastel colours for midtones, core shadow, caste shadow & reflection.



6. Poster colours also you can use, if you are good in that.



Question Paper
ELEMENTARY GRADE EXAMINATION

OBJECT DRAWING

(First Paper)

Total Time: 2 1/2 Hours]

(First Day)

[Time: 10.30 am to 1.00 pm]

Special instructions:

- (1) Mechanical devices should not be used. (2) No credit will be given for small pictures. (3) It is expected that the group of objects should be drawn the way it is seen from individual's position.
- (1) Drawing should not be small. It is very important to arrange or compose the group of objects harmoniously and in proportion to the rectangle. (2) The characteristic forms of all objects and their relative proportions drawn on paper should appropriately suit the objects kept in the front. (3) Colour the picture reflecting their shade and light, texture and colours, as you see and feel them. However, your chief aim should be to create a beautiful composition.
- (4) You may use any one of the media singly or in combination, as needed, to enhance the beauty of your picture.
- Water colour: Transparent and / or opaque.
Crayons: Oil and / or wax and coloured pencils.
-

MEMORY DRAWING

(Second Paper - First Day)

Exam Timings 2.00 pm to 4.00 pm (2 Hours)

1. Syllabus:

(1) To illustrate a past event / scene from one's daily life. (2) To create a picture with three to four human figures, suggestive elements related to the topic and an appropriate background. (3) To develop the power of imaginative reconstruction and ability to effectively express an idea pictorially.

2. Suggested media:

(1) Pencils (2) Transparent and / or opaque water colours (3) Oil pastels or wax crayons (4) Various coloured inks (5) Natural colours. You may use these media individually or in combination.

3. Topics: (1) Incident / event / scene from daily life (2) Family event (3) School / Classroom (4) Sports scene (5) Values such as Dignity of labour, gender equality, cleanliness, National unity, etc. (6) National/Religious festival/event. Suggestive elements related to the topic and an appropriate effective background is expected in the drawing.

Materials:

1. A3 portable drawing pad/board
2. HB/2B pencil with sharpener & eraser
3. Cotton rag to clean brush & No spill pot
4. 24 shades Water colour cakes
5. No.-2/4/6 Round - fine golden taklon hair brush
6. camlin-brush-pens-6-shades for outline.



Method: (e.g. topic: my birthday being celebrated by my mother, father and sister)

1. Draw 1.5cm border without using a scale.
2. Staging/positioning/composing 3/4 figures.



Do detailed drawing.



3. a) Apply flesh tint/skin colour/peach colour from water colour cakes on body parts of the figures.
b) Apply water colours on other parts.
c) Apply water colours on dark tones & shadow portion.
d) Use brush pens for outlining.



Question paper
ELEMENTARY GRADE EXAMINATION
MEMORY DRAWING (Second Paper)

Total Time: 2 hours]
(First Day)
[Time: 2.00 pm to 4.00 pm]

Special instructions:

- (1) No mechanical devices should be used.
(2) No credit will be given for a comparatively small picture.
You may use the following media for your work singly or in combination.
Water colours: Transparent and/or Opaque.
Pastels: Oil Pastels or Wax Crayons.

General Instruction: Make a rapid sketch in pencil and colour the same sketch to make a picture on (any one) of the following subject/incidents. But your drawing must be in colour.

Question Paper (2015):

1. My birthday being celebrated by my mother, father and sister.
2. Two boys and two girls doing experiment in the laboratory.
3. Three school boys/girls helping a villager who is doing tree plantation on the roadside.

DESIGN

(Third Paper - Second Day)

Exam Timings: 10.30 am to 1.00 pm (2^{1/2} Hours),

1. Syllabus: (1) A design is done within the outer shape of any geometric figure. (E.g. square, rectangle, triangle, circle, semi-circle, regular polygon, etc.) (2) A decorative design can be made by creatively using different types of lines, (straight lines, curved lines, rhythmic lines, etc.), natural, geometric, ornamental or abstract shapes. (3) Symmetrical or asymmetrical design. (4) Design using appropriate / any colour scheme of your choice and / or use of textures. (Mechanical instruments can be used.)
2. Suggested media: (1) Water colour, (Transparent / Opaque) (2) Coloured pencils, Wax crayons (3) Oil pastels (4) Various coloured inks (5) Naturally available colours. These media may be used individually or in combination. (6) If texture is desired, then various materials and tools, e.g. rags, fingers, crumpled paper, leaves, comb or stamps may be used.
3. Topics: Compose a design using straight lines, curved lines, rhythmic lines, various natural, geometric, ornamental or abstract shapes within any geometric shape (e.g. square, rectangle, triangle, circle, semi-circle or regular polygon.)

Materials:

1. A3 portable drawing pad/board
2. HB/2B pencil with sharpener & eraser
3. Cotton rag to clean brush & No spill pot
4. No.2/4/6 Round - fine golden taklon hair brush
5. Poster or tempera - Opaque colours are good for Design.



6. Geometry box.



Practice:

Question 1: Draw an outer shape of a table lamp to suit the paper and draw a beautiful design in it with the help of following units and a suitable colour scheme.

- (1) Three circles of unequal sizes. (2) Two triangles of unequal sizes. (3) Three fish of unequal sizes. (4) Three curved lines.



Question 2: Draw a 20cm square. In this square, draw an attractive design with the help of the following units and a suitable colour scheme:

- (1) Two or three rhythmic lines.
- (2) Three circles of unequal sizes.
- (3) Two unequal squares.
- (4) Two forms of flowers or leaves.
- (5) Colour the design with suitable colour scheme.



Question 3: Construct a hexagon with its side measuring 9cm. In this hexagon, draw a design with the help of the following units and a suitable colour scheme

(1) Three circles of unequal sizes. (2) Three squares of unequal sizes. (3) Three triangles of unequal sizes. (4) Two straight or curved lines.

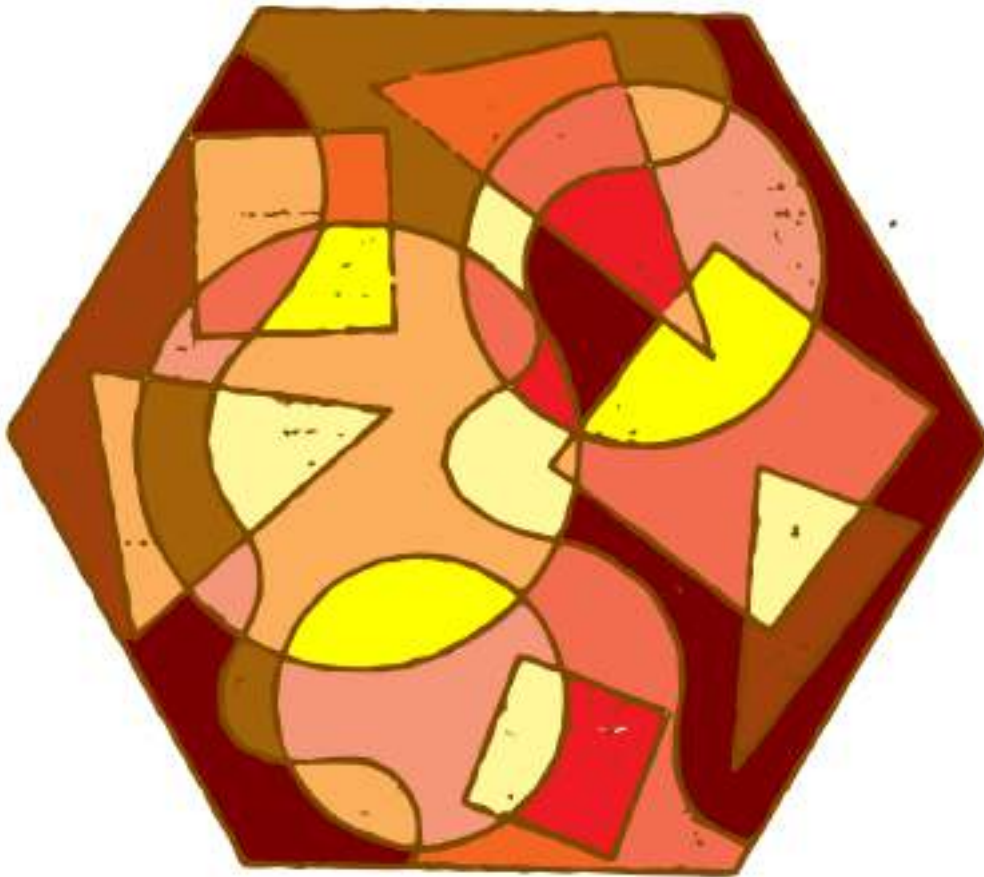

Question paper
ELEMENTARY GRADE EXAMINATION

DESIGN

(Third Paper)

Total Time: 2 1/2 Hours]

(Second Day)

[Time: 10.30 am to 1.00 pm]

Special instructions: (1) To use Geometrical instruments to make outer shape based on geometric shapes.

(2) Neatness and accuracy in colouring is important. (3) Creativity, imagination and originality is expected in creating good design.

You may use one or a mixture of the following media.

Water colours: Transparent / Opaque.

Pastels: Wax crayons, Oil Pastels.

Other Media: Coloured pencils, various coloured inks.

General Instruction: To create a design by composing the given shapes.

Question Paper (2015):

Draw a square of 17 cm. Create a beautiful design using your imagination with the help of the following elements. (a)

Three unequal circles. (b) Two triangles. (b) Decorative shapes of two flowers or leaves. (d) A straight or curved line according to necessity.

PLANE GEOMETRY & LETTERING

(Fourth Paper – Second Day)

Exam Timings 2.00 pm to 4.00 pm (2 Hours)

Section 'A': Plane Geometry

1. Syllabus:

(1) To bisect a given straight line.

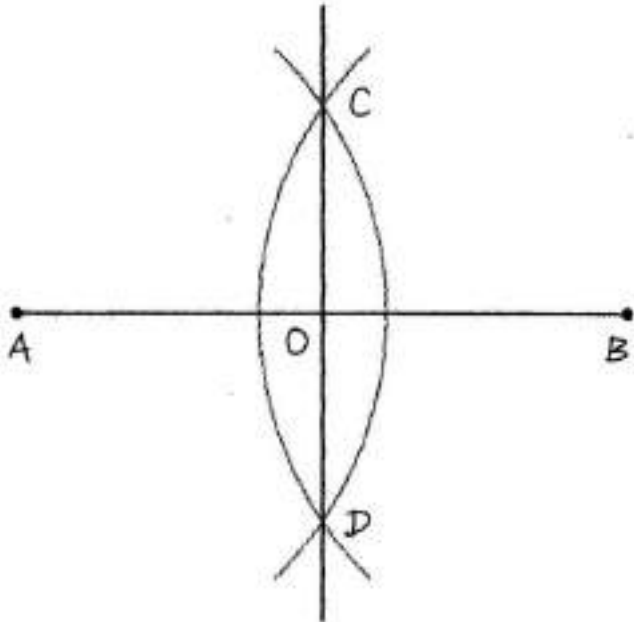

(2) To divide a given line into 4 or 8 equal parts.

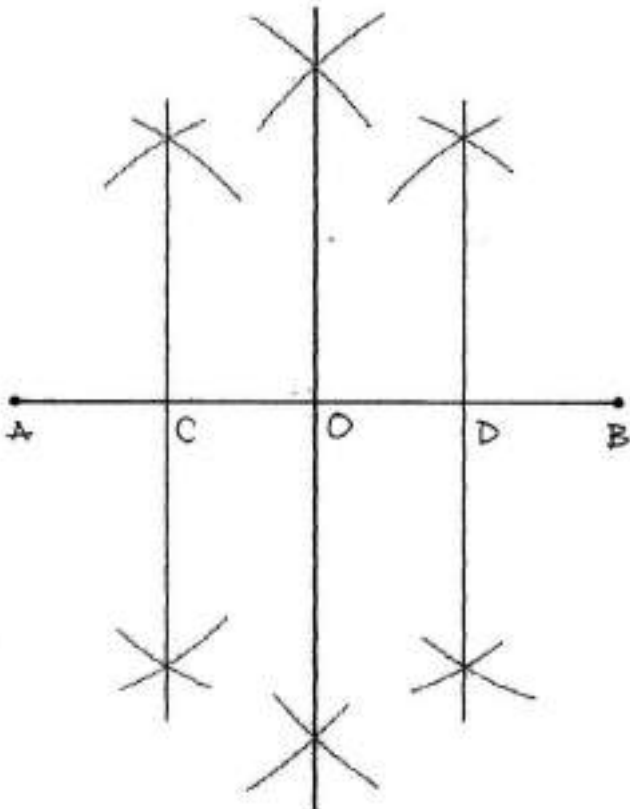

(3) To divide a given line into any number of equal parts.

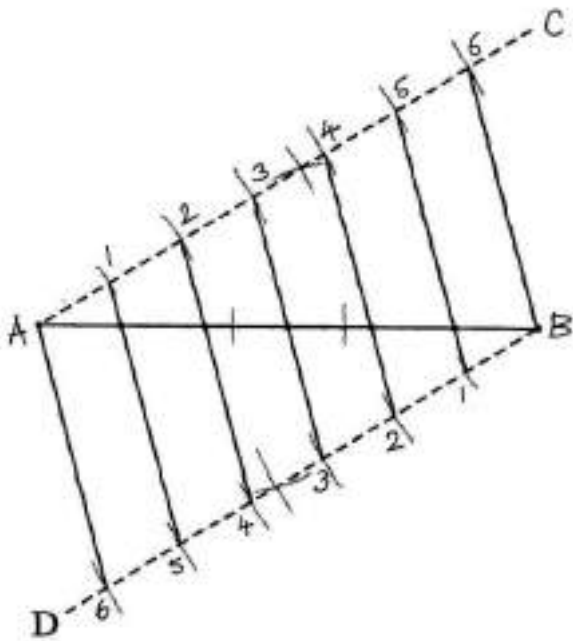

(4) To draw a perpendicular to a given line from the given point on it.

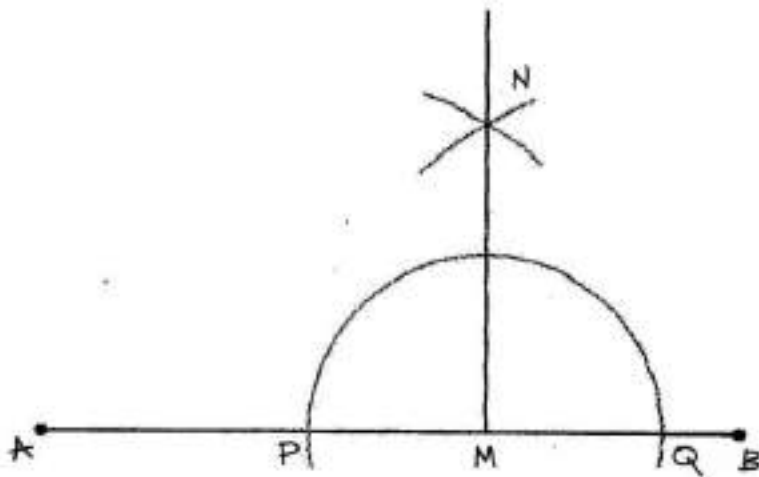

(5) To draw a perpendicular to a given line from the given point outside it.

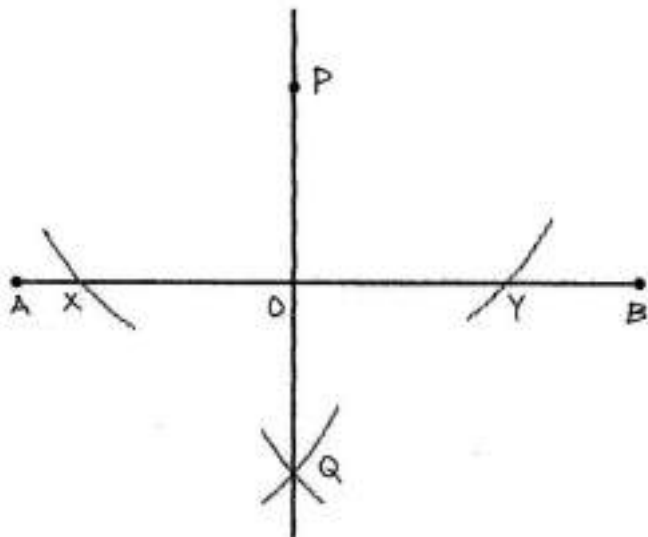

(6) To bisect a given angle.

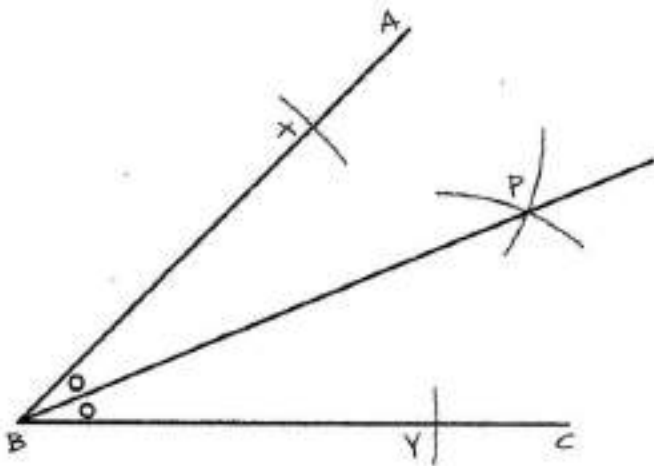

(7) To trisect a right angle without using a protractor.

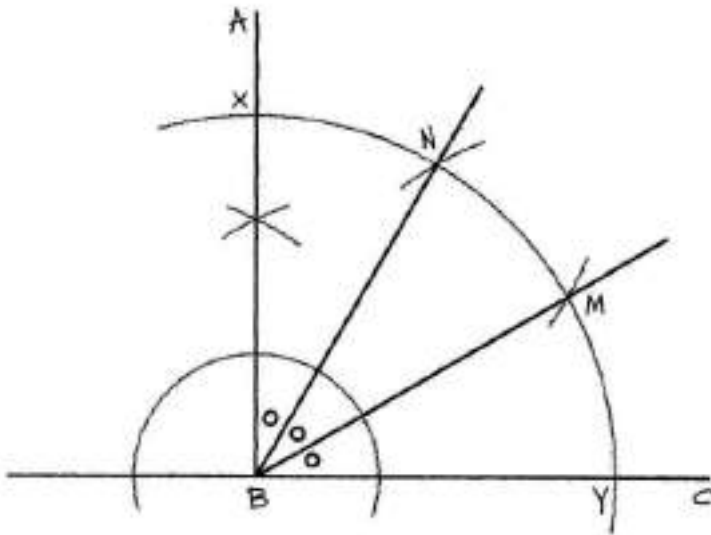

(8) To construct an equilateral triangle on a given base.

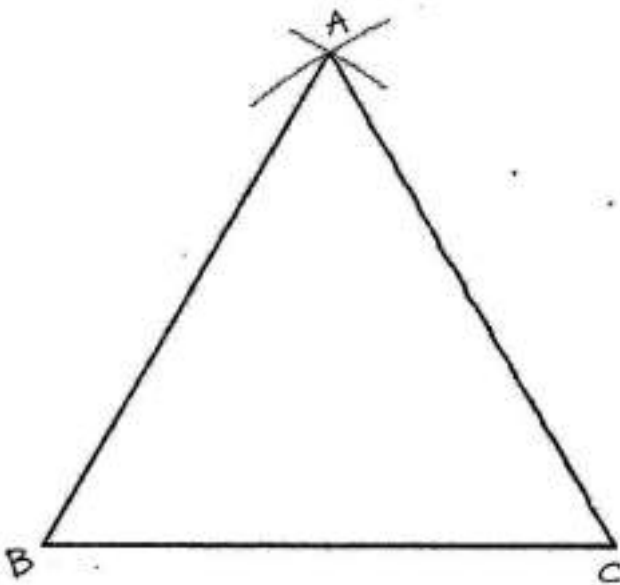

(9) To construct an isosceles triangle, one of the equal sides and one of the equal angles being given.

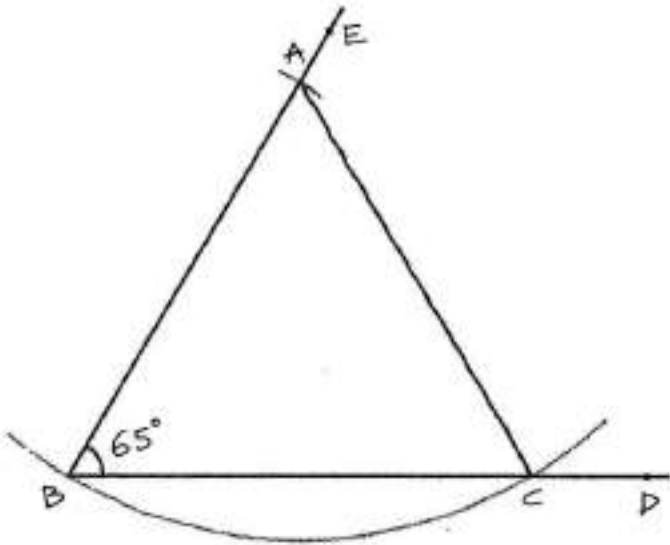

(10) To construct a triangle, its base and the two angles at the base being given.

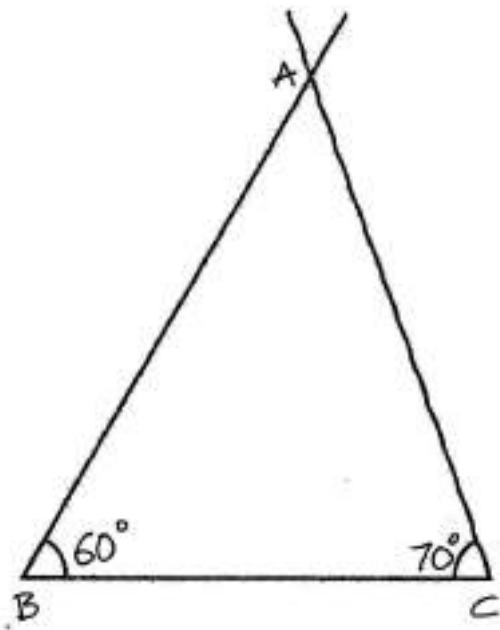

(11) To construct a triangle, its three sides being given.

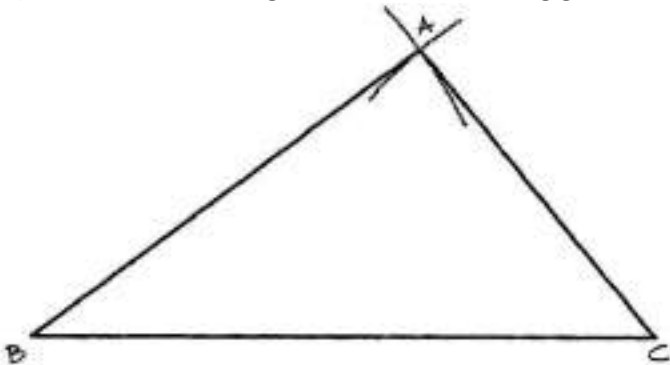

(12) To construct a square on a given base.

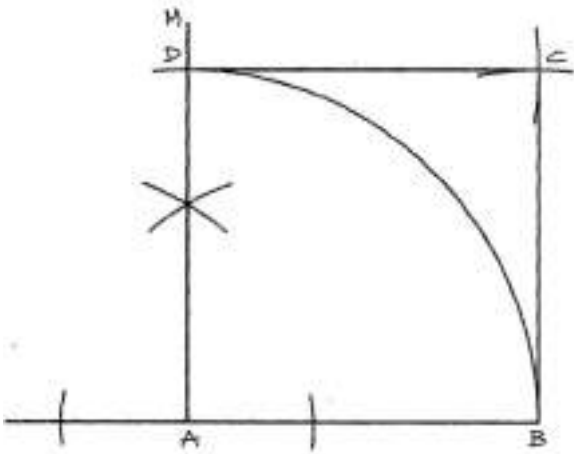

(13) To construct a square, its diagonal being given.

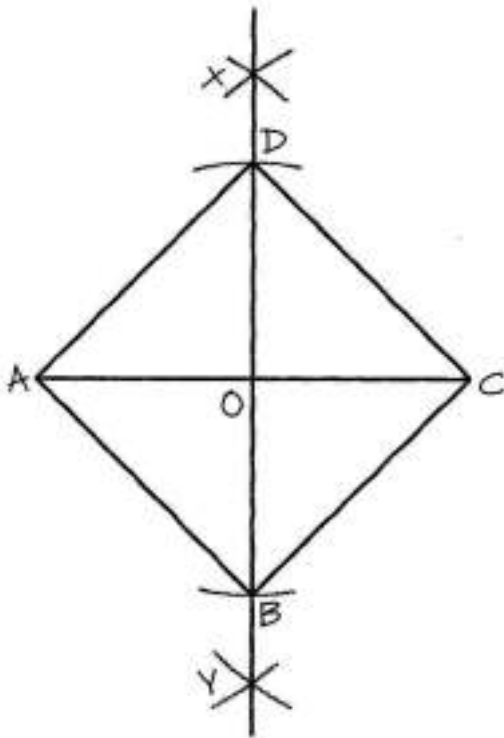

(14) To construct a rectangle, its two unequal sides being given.

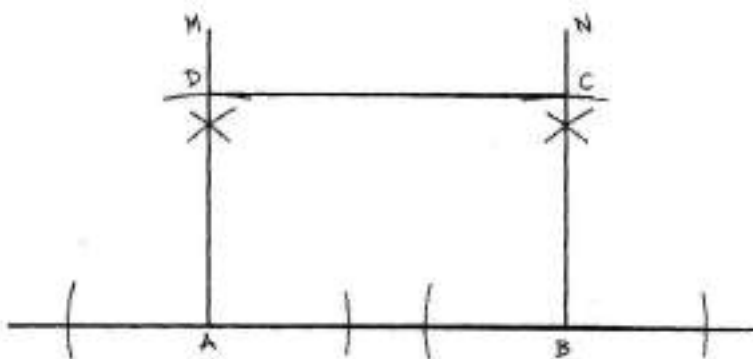

(15) To divide a given circle into four / six / eight equal parts.

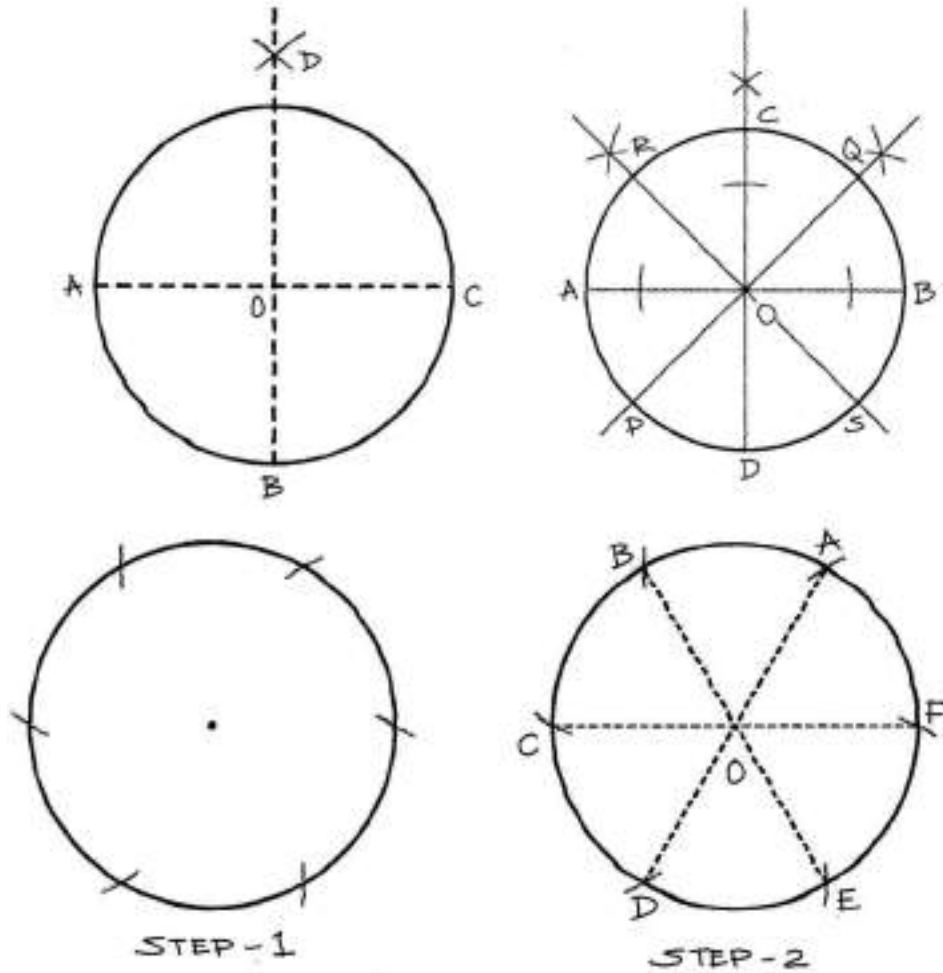

(16) To construct a regular Polygon with one of its sides given. (e.g. Pentagon, Septagon, etc.)

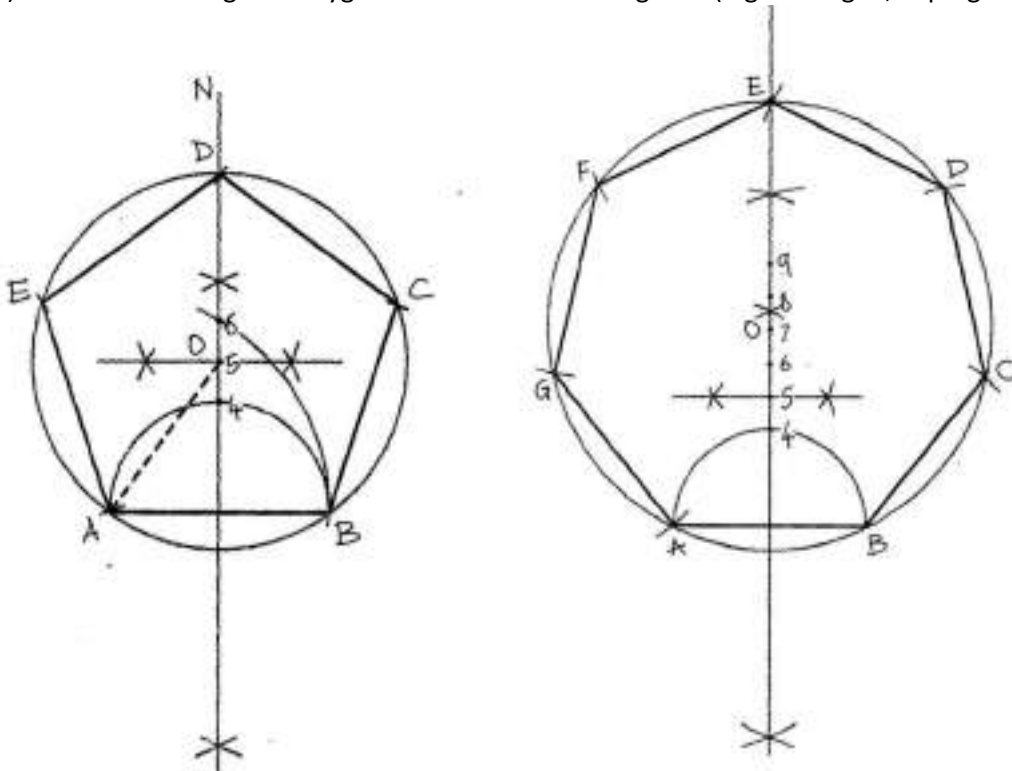

(17) To inscribe a circle in a given triangle.

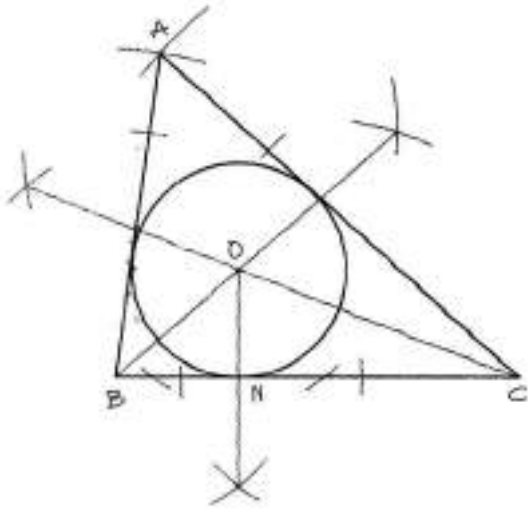

(18) To inscribe a circle in a square.

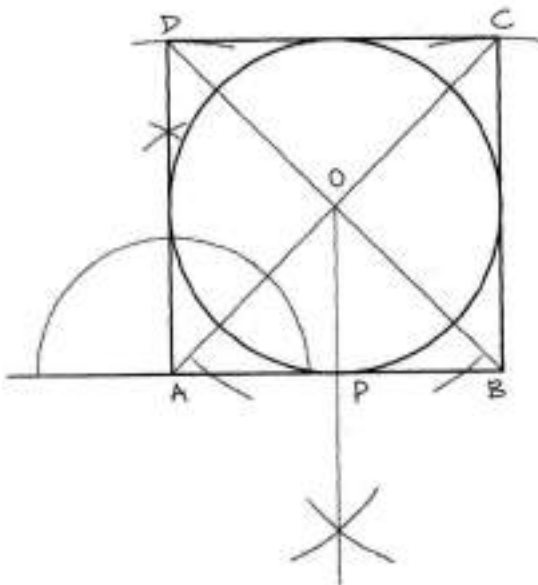

(19) To inscribe 3 equal circles in an equilateral triangle in such a way, that each circle will touch one side of the triangle and the two other circles.

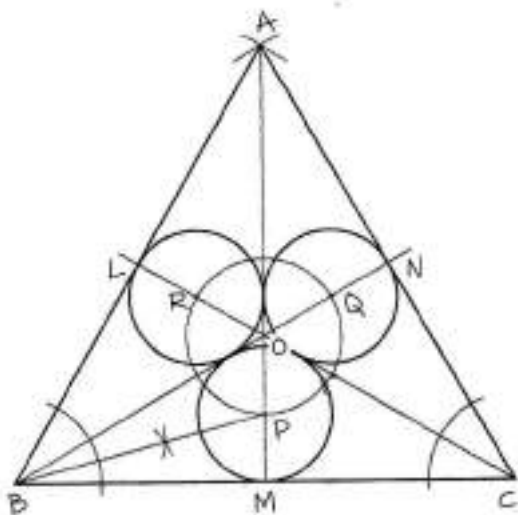

(20) To inscribe 4 equal circles in a given square in such a way, that each circle will touch one side of the square and the two circles.

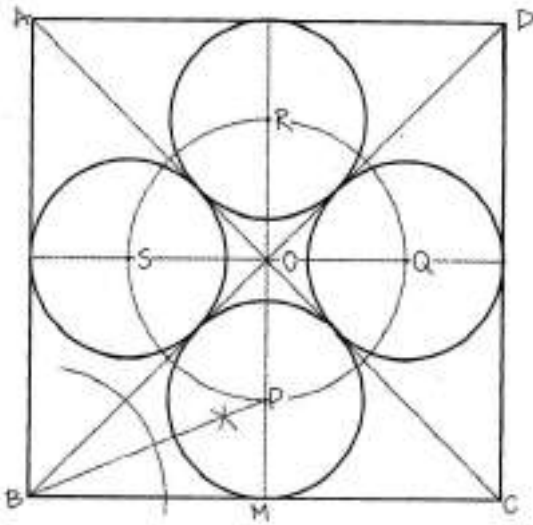

Section 'B': Lettering

Draw the word/title given in the question paper in outer shape, along with an expressive symbol, appropriate to its meaning and colour them with colours of your choice.

2. Suggested medium:

For Geometry - Pencil and / or Pen.

For Lettering - Any medium.





Question paper
ELEMENTARY GRADE EXAMINATION
PLANE GEOMETRY & LETTERING

(Fourth Paper)

Total Time: 2 Hours]

(Second Day)

[Time: 2.00 pm to 4.00 pm]

Instructions for candidates: (1) Solve any four questions from Section 'A'. (2) It is compulsory to solve the question of 'Lettering' from Section (3) All the lines drawn in the diagram should be permanent. They should not be erased. (4) Special attention should be given to neatness and accuracy. (5) Both sides of the paper can be used. (6) In Lettering, draw the outer shape of your choice. Inside the outer shape, interpret the word/title according to the meaning of the word or in your own style and colour it with colours of your choice.

For Geometry: Pencil or Pen

For Lettering: Colour medium of your choice.

Tools: Mechanical instruments of Geometry Box.

Question Paper (2015):

SECTION 'A' - PLANE GEOMETRY

Solve any four questions from Section 'A':

1. Side AB = 9cm. Side BC = 7cm and side AC = 6cm. Draw a triangle ABC.
2. Draw a line PQ = 11cm. Divide that line in four equal parts.
3. Draw a square MNOP having side 7cm. Draw a circle touching sides of the square internally.
4. Draw a circle of 4.5 cm radius and divide the circle in eight equal parts.
5. $\angle ABC = 75^\circ$. Draw the angle. Divide this angle in two equal parts without using a protractor. Use only compass.

SECTION 'B' - LETTERING

Answer the question given below. It is Compulsory:

On the answer paper, draw an outer shape of your choice. Inside this outer shape, interpret the word/title given below according to the meaning of the word or in your own style and colour it with colours of your choice.

' कलारंजन ' or 'KALARANJAN'

Intermediate Grade Drawing Examination

STILL LIFE

(First Paper - First Day)

Exam Timings: 10.30 am to 1.30 pm (3 Hours)

1. Syllabus:

(1) To draw and colour a group of 4 to 6 man-made and natural objects of different sizes arranged before you, as per your perception. The drawing must be made along with the background and foreground drapery. (2) Natural objects like leaves, flowers, fruits, vegetables, etc., may also be included. (3) To aesthetically render a group of objects arranged before you, with proportionate size and shape. (4) To give importance to aesthetic arrangement of objects, proportion to other objects, shade and light, texture and presentation. (5) Mechanical devices should not be used. (The objects may be arranged on the floor or above at a suitable height.)

2. Suggested media:

(1) Coloured pencils (2) Wax crayons (3) Water colours. (Transparent/Opaque) (4) Oil pastels (5) Various coloured inks (6) Natural colours or any of these media can be used individually or in combination. Similarly, various techniques can be used to complete the picture.

3. Arranged Objects: (1) An arrangement of man-made and natural objects. (2) Appropriately coloured foreground and background drapery.

Materials:

1. A3 portable drawing pad/board. (Navneet A3 drawing pad)
2. HB/2B pencil with sharpener & eraser. (Apsara HB/2B pencil box with free eraser & sharpener)
3. Cotton rag to clean brush & No spill pot/water container.
4. 24 shades Water colour cakes.
5. 15 shades Oil pastel colours.
6. No.-2/4/6 Round - fine golden taklon hair brush.

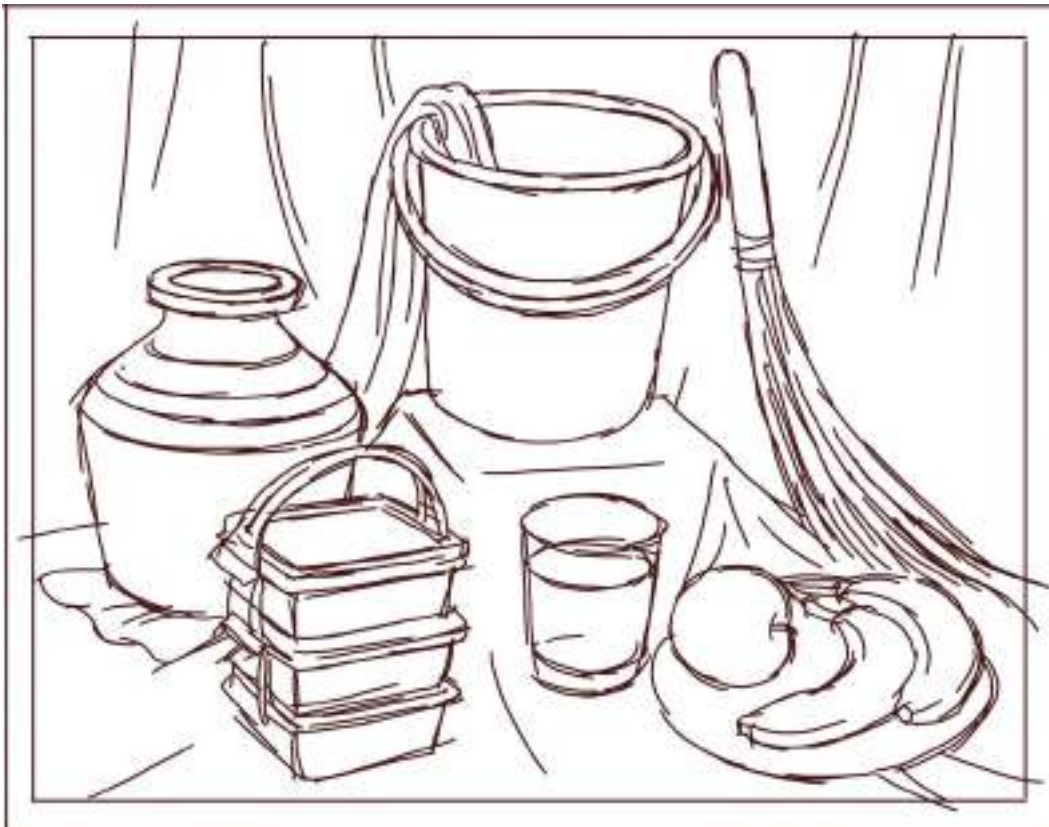



Question papers
INTERMEDIATE GRADE EXAMINATION
STILL LIFE
(First Paper)
Total Time: 3 Hours]
(First Day)
[Time: 10.30 am to 1.30 pm]

Special instructions:

(1) Mechanical devices should not be used. (2) No credit will be given for small pictures. (3) It is expected that the group of objects should be drawn the way it is seen from individual's position.

Question Paper (2015):

(1) Draw a freehand border leaving about 2 cm margin on all four sides of the paper. (2) Draw the group of objects placed before you in the rectangle, large enough to suit the size of the paper. (3) Organizing the group of objects in the rectangle harmoniously and proportionately is very important. To make the drawing more impressive, you are allowed to make minor changes in the placement of the objects or proportion of the objects with each other or the size of the objects. 4) The characteristic forms of objects and relative proportions should suit the creation of your picture. 5) Colour the drawing showing shade and light, texture and colours, as you feel them and while doing so, creation of beauty should be your chief aim. 6) You may use any one of the media or in combination, as needed, with a view to enhance the beauty of the picture.

Water colours: Transparent and/or Opaque.

Crayons: Oil and/or Wax and Coloured pencils.

MEMORY DRAWING

(Second Paper - First Day)

Exam Timings 2.30 pm to 4.30 pm (2 Hours)

1. Syllabus:

(1) To illustrate a past event /scene from one's daily life. (2) To create a picture with four or more human figures, suggestive elements related to the topic and an appropriate background. (3) To develop the power of imaginative reconstruction and ability to effectively express an idea pictorially. (4) More emphasis should be given to create an imaginative drawing related to the given topic rather than just making a neat and accurate drawing. (5) To complete the entire picture with colouring.

2. Suggested media:

(1) Pencils (2) Transparent and / or opaque water colours (3) Oil pastels or wax crayons (4) Various coloured inks (5) Natural colours. You may use these media individually or in combination.

3. Topics: (1) Incident / event / scene from daily life (2) Family event (3) School / Classroom (4) Sports scene (5) Values such as Dignity of labour, gender equality, cleanliness, National unity, etc. (6) National/Religious festival/event. (7) Festivals, gathering, procession, crowded places (e.g., railway station, market, garden) (8) Village scene (9) Local cultural event.

Materials:

1. A3 portable drawing pad/board
2. HB/2B pencil with sharpener & eraser
3. Cotton rag to clean brush & No spill pot
4. 24 shades Water colour cakes
5. No.-2/4/6 Round - fine golden taklon hair brush
6. camlin-brush-pens-6-shades for outline.





Question paper
INTERMEDIATE GRADE EXAMINATION
MEMORY DRAWING
(Second Paper)
Total Time: 2 hours]
(First Day)
[Time: 2.30 pm to 4.30 pm]

Special instructions:

(1) No mechanical devices should be used. (2) No credit will be given for a comparatively small picture.

You may use the following media for your work singly or in combination.

Water colours: Transparent and/or Opaque.

Pastels: Oil Pastels or Wax Crayons.

General Instruction: Make a rapid sketch in pencil and colour the same sketch to make a picture on (any one) of the following subject/incidents. But your drawing must be in colour.

Question Paper (2015):

1. A villager participating in the Village-Cleanliness Drive.
2. An event which I liked in a wedding ceremony.
3. Students decorating the class and the teacher guiding them.

DESIGN

(Third Paper - Second Day)

Exam Timings 10.30 am to 1.30 pm (3 Hours)

1. Syllabus: (1) To prepare a design within the outer shape of any given/specific object. (2) Design has to be created using different types of lines, geometric shapes as well as shapes of leaves, flowers, fruits, birds, butterflies, fish, animals, etc. Forms can be natural, decorative or abstract in shape. (3) Compose the design within the outer shape symmetrically or asymmetrically or however you like. (4) Design may be coloured using any colour scheme/colour combination of your choice. (5) Importance will be given to finishing of colouring and neatness. (6) To make the design look more attractive, texture can be added and various techniques can be used.

2. Suggested media: Colour medium used for Elementary can be used for Intermediate as well. Tracing can be done.

3. Topics : (1) Hand fan (2) Table lamp (3) Table top (4) Carpet (5) Teapoy (6) Vase (7) Tray (8) Saree border (9) Purse (10) Cloth (11) Kite (12) Handkerchief (13) T.V. cover (14) Pillow cover (15) T-shirt (16) Lantern (17) Tiles. Prepare natural, decorative or abstract design in any of these object shapes using different lines, geometric shapes, shapes of leaves, flowers, fruits, birds, fish, butterflies, etc.

Materials:

1. A3 portable drawing pad/board
2. HB/2B pencil with sharpener & eraser
3. Cotton rag to clean brush & No spill pot
4. No.2/4/6 Round - fine golden taklon hair brush
5. Poster or tempera - Opaque colours are good for Design.



6. Geometry box.





Question paper
INTERMEDIATE GRADE EXAMINATION
DESIGN

(Third Paper)

Total Tim, 3 Hours]

(Second Day)

Time: 10.30 am to 1.30 pm

Special instruction: Neatness and accuracy in colouring is important.

(1) To create a symmetrical, asymmetrical design of your choice within a given outer shape. (2) To make the design more attractive by using textures and various techniques. (3) Use tracing method wherever required.

You may use any one or a combination of the following media:

Water colours: Transparent / Opaque.

Pastels: Wax crayons, Oil pastels.

Other media: Coloured inks, Natural colours.

General instruction: To create a design by composing the given shapes.

Question Paper (2015):

Draw the outer shape of a 'T-shirt' holding the answer paper vertically according to your liking (Height of the T-shirt should not be less than 18cms.). Inside this shape, create a beautiful design using elements of your choice in symmetrical or asymmetrical technique and colour it with suitable colours.

PLANE GEOMETRY, SOLID GEOMETRY AND LETTERING

(Fourth Paper – Second Day)

Exam Timings 2.30 pm to 5.30 pm (3 Hours)

Syllabus:

Section 'A': Plane Geometry

(1) To draw a line parallel to a given line from a given point.

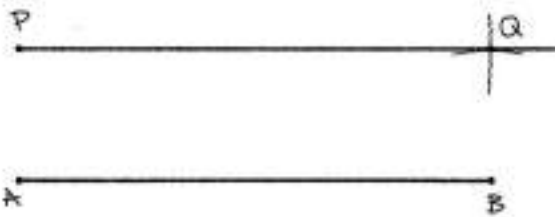

(2) To draw a line parallel to a given line at a given distance from it.

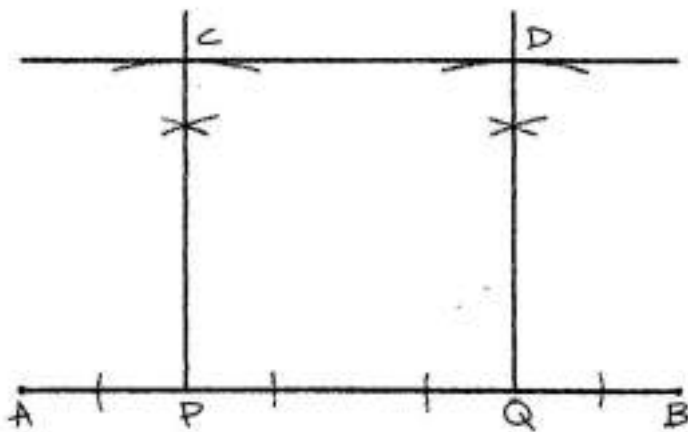

(3) To divide a line in proportion to the divisions of a given line.

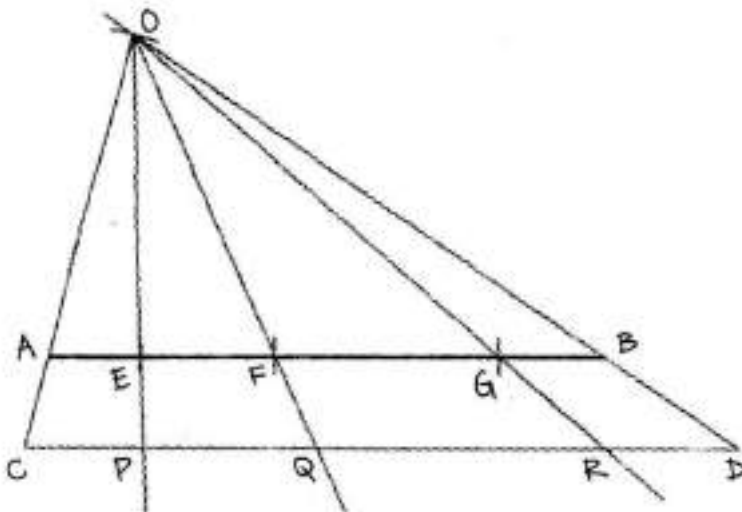

(4) To divide a given angle into two / four equal parts.

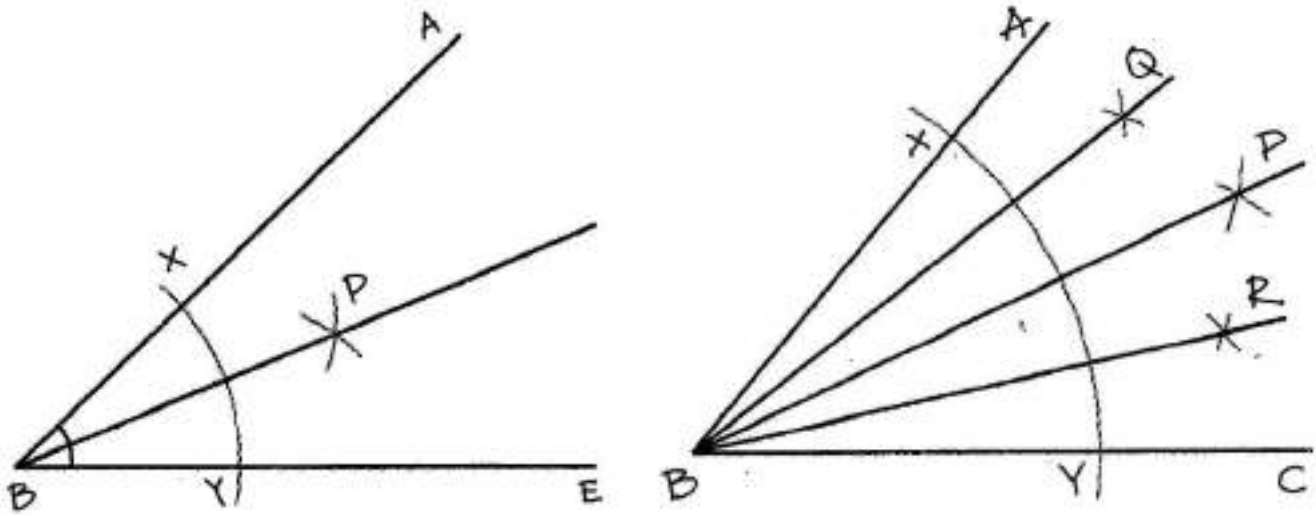

(5) To construct a right angled triangle, its hypotenuse and one acute angle being given.

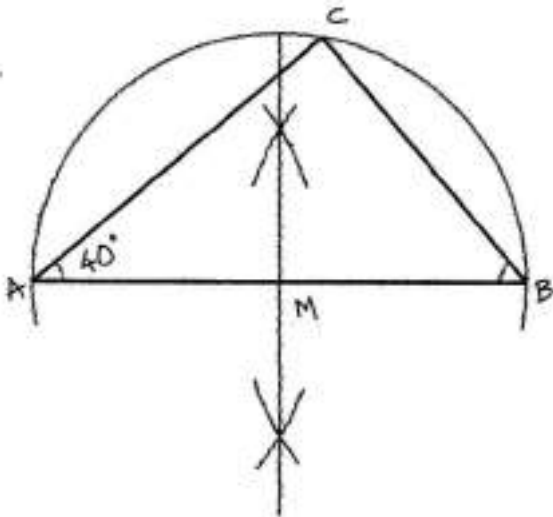

(6) To construct a right angled triangle, its hypotenuse and one side being given.

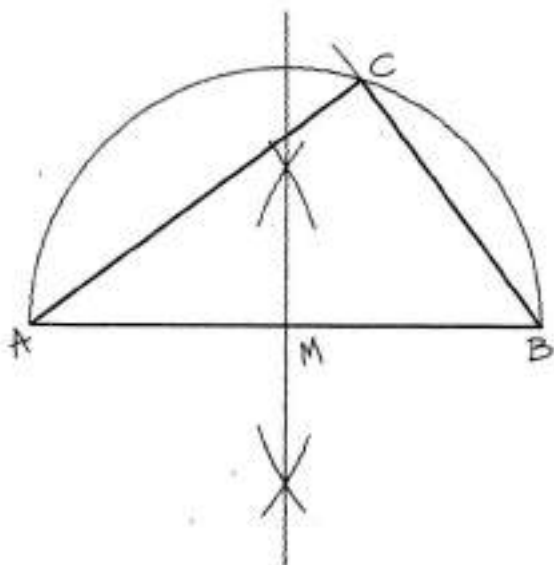

(7) To construct a rhombus, the base and one angle being given.

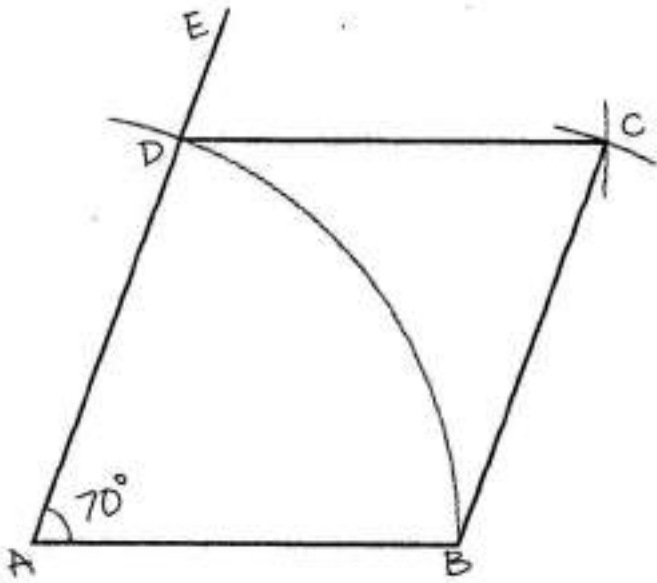

(8) To construct a rhombus, the diagonal and one side being given.

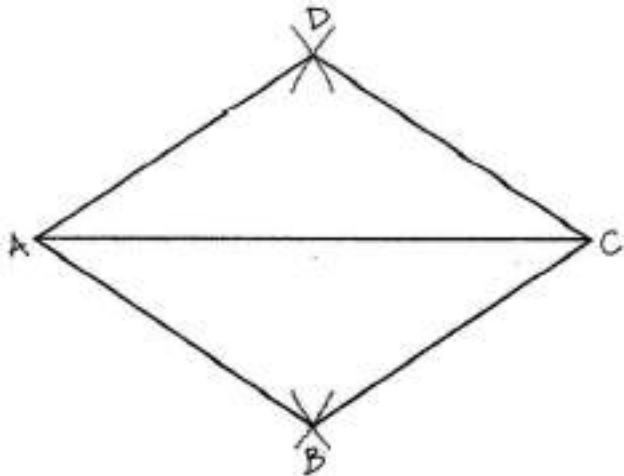

(9) To construct a rhombus, its two diagonals being given.

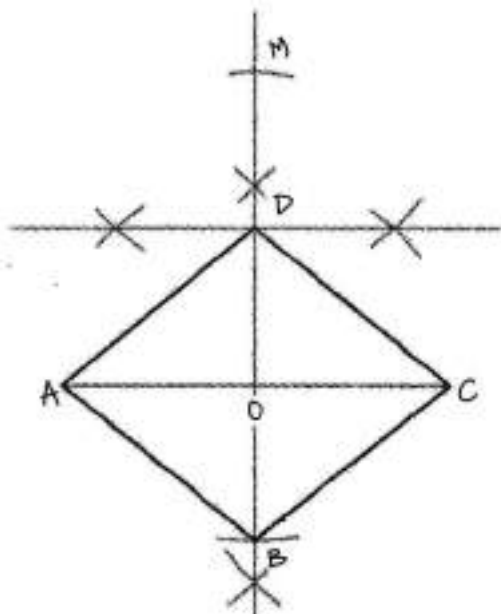

(10) To construct a parallelogram, its two adjacent sides and the angle between them being given.

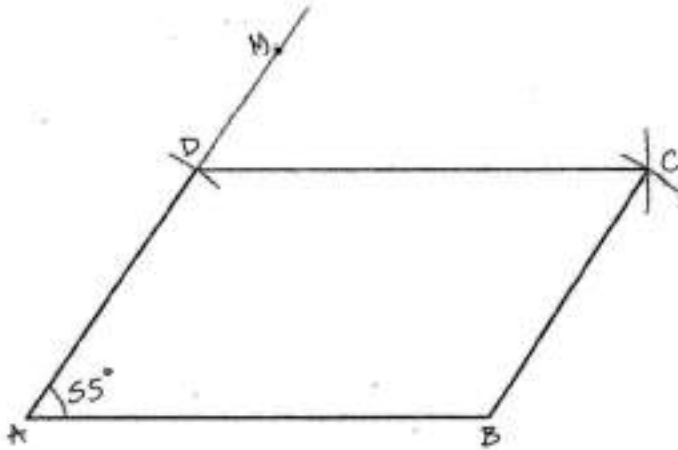

(11) To construct a kite, its two unequal sides and the angle contained by these sides being given.

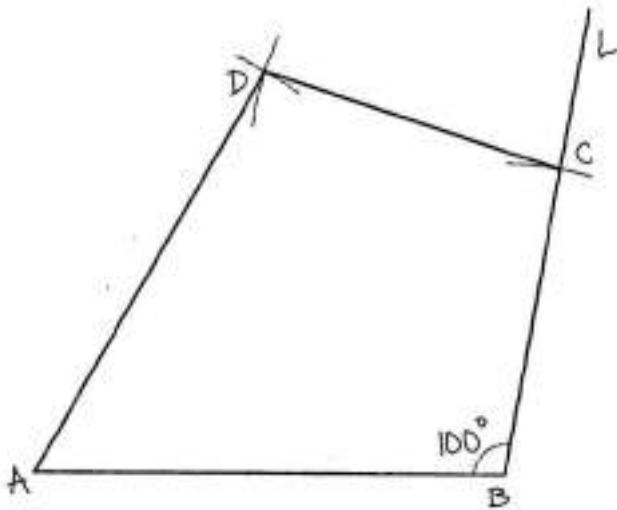

(12) To describe a circle (or an arc) passing through three given points, not in a straight line.

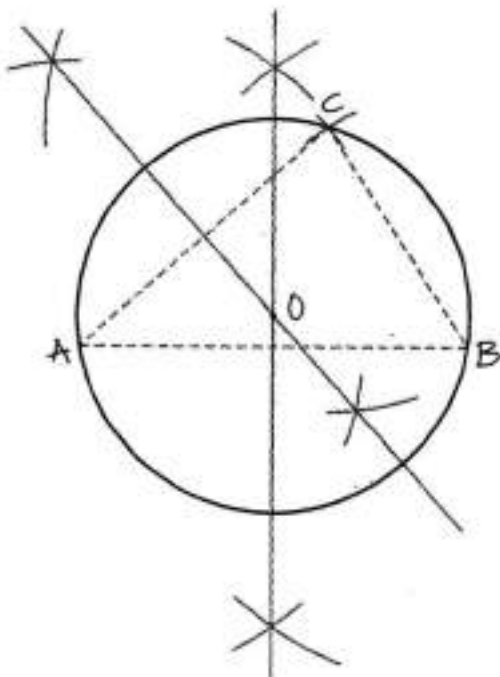

(13) To inscribe a circle in rhomboid (kite).

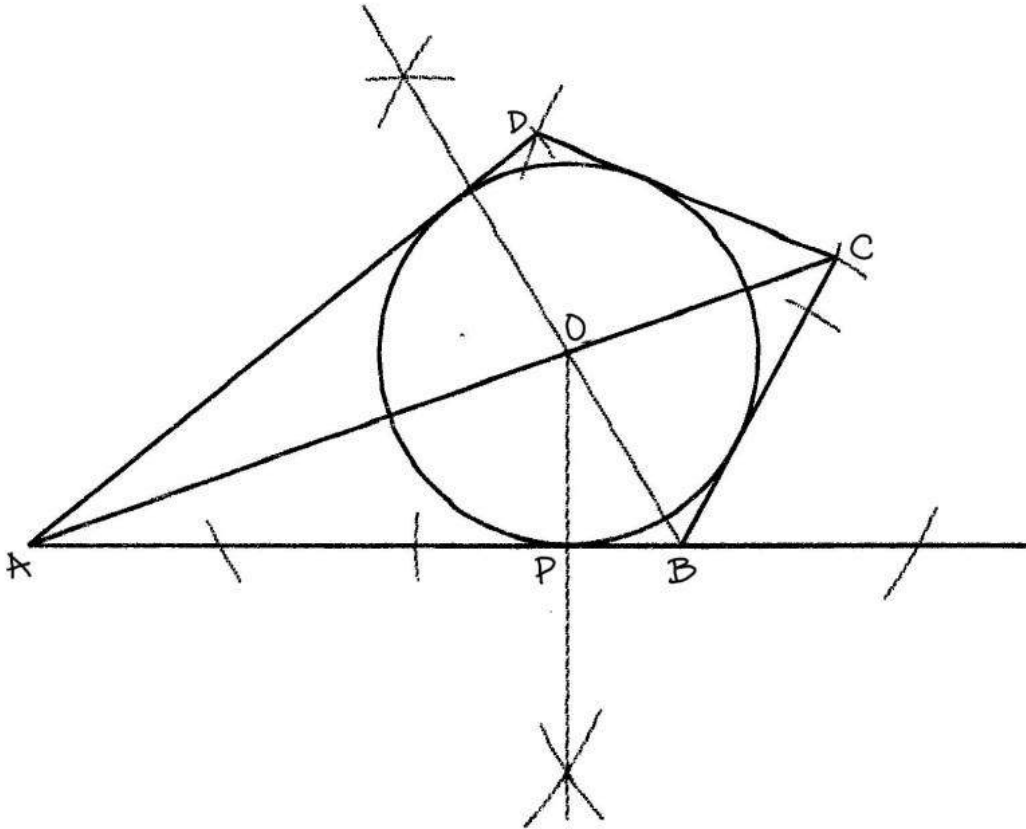

(14) To inscribe 3 or 4 circles in a given regular triangle (equilateral triangle) or square in such a way that each circle will touch two sides of the triangle or square and two other circles.

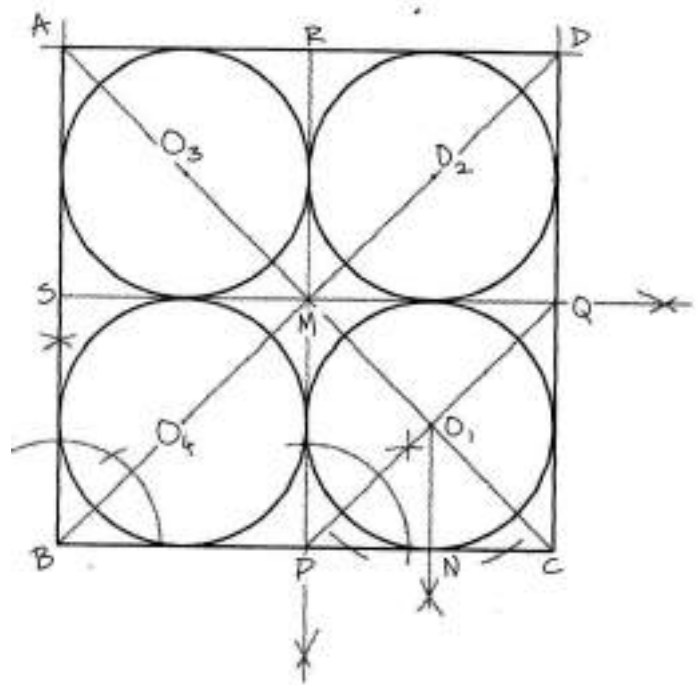
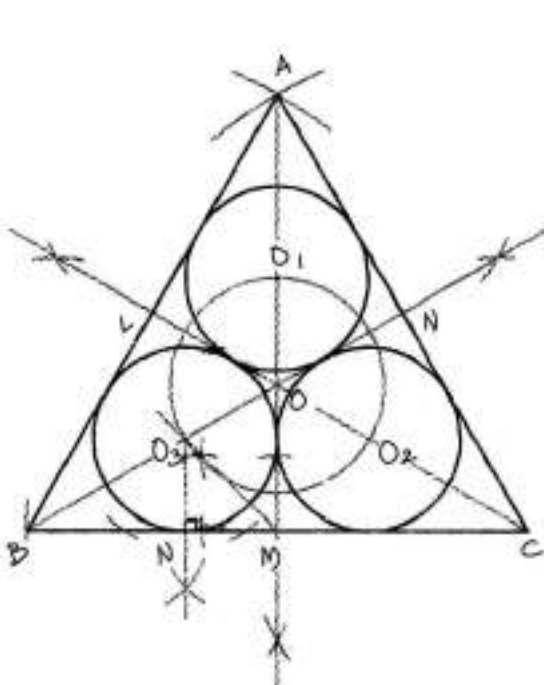

(15) To inscribe a circle in a sector.

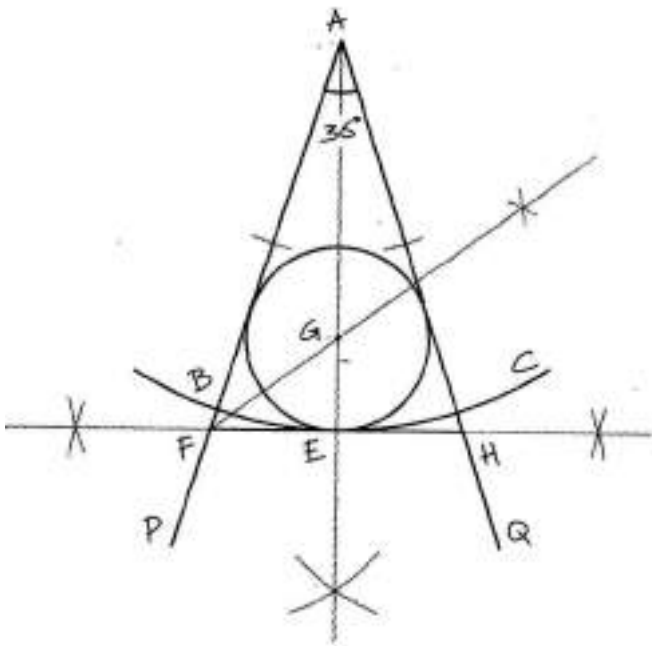

(16) To inscribe a circle of given radius to touch two converging lines.

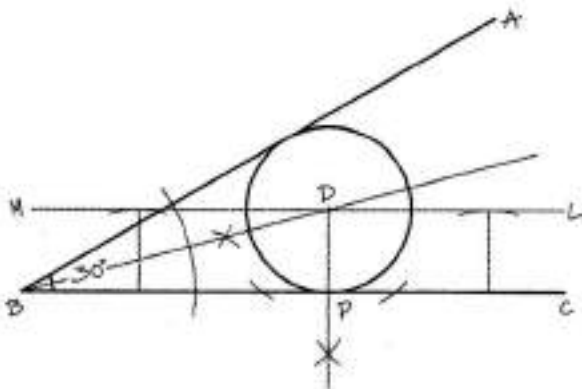

(17) To inscribe three equal semicircles in an equilateral triangle, each semicircle touching one side of the triangle and their diameters to be adjacent.

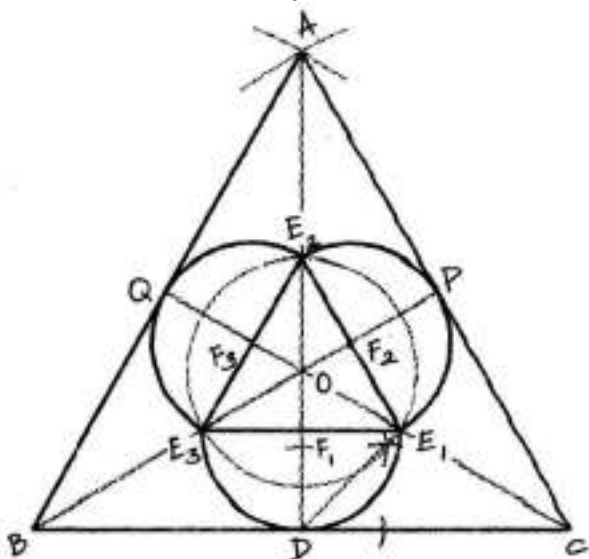

(18) In a given square, to inscribe four equal semicircles, each to touch two sides of the square and their diameters to be adjacent.

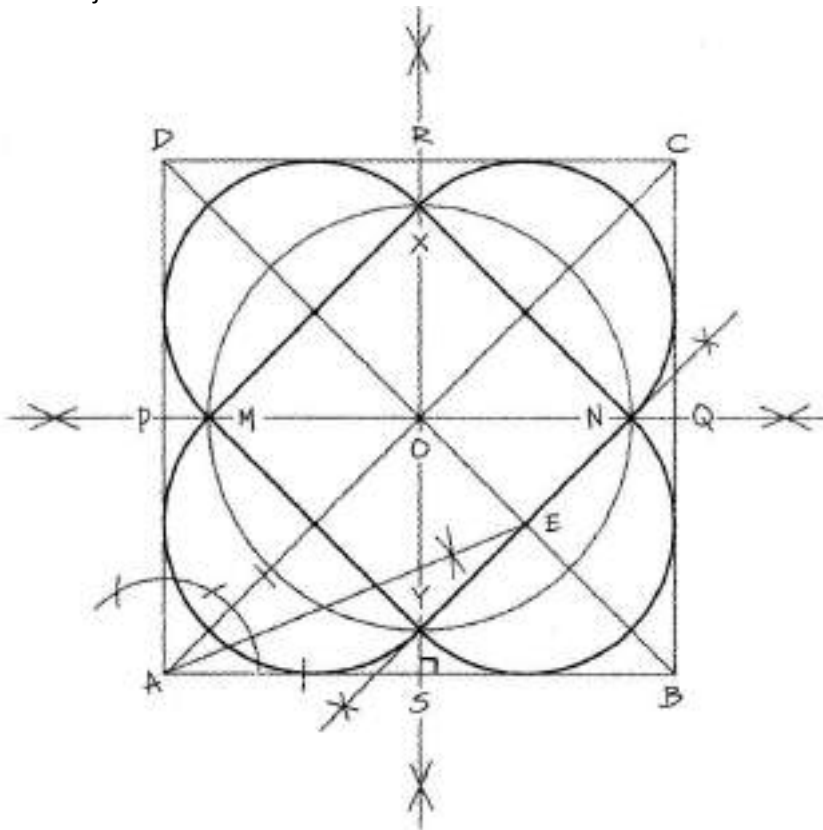

(19) To inscribe a semicircle in a sector.

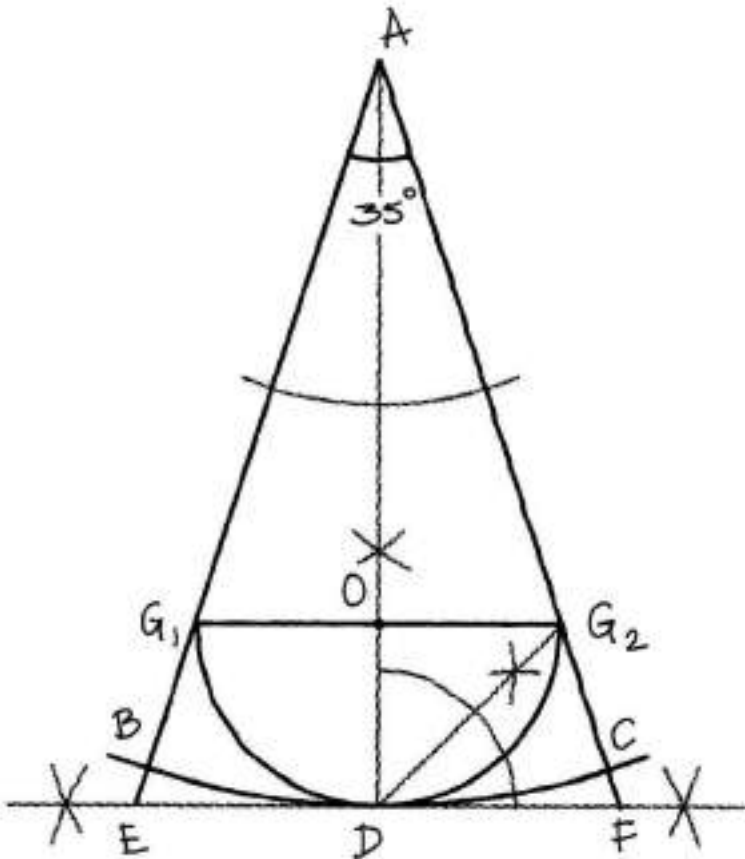

(20) In a given circle, to inscribe four equal semicircles, each to touch the circumference and their diameter to be adjacent.

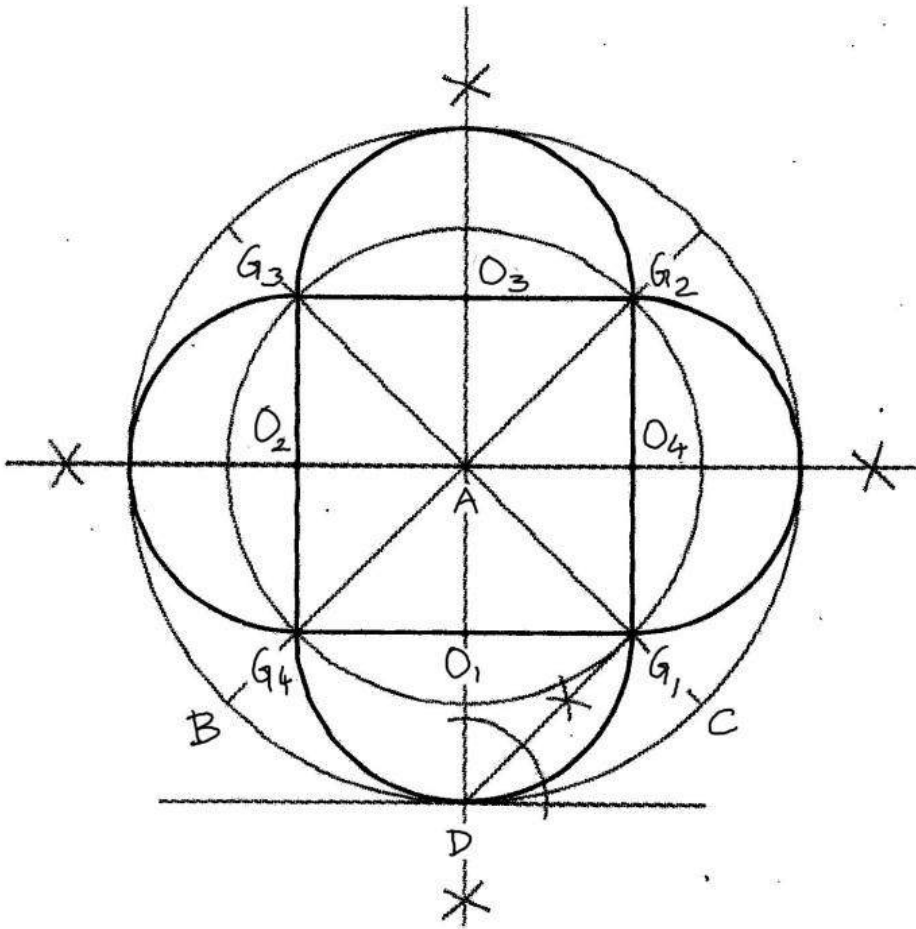

Section 'B': Solid Geometry and Lettering

- (1) To draw the plan and elevation of solid objects like Cube, Square prism, Cylinder, Cone, Pyramid and Sphere.
- (2) To write the given word attractively, name or title within the given outer shape.
- (3) To artistically express the meaning of the word through creative lettering.
- (4) Write the lettering in Roman letters or its adaptations or in any regional script. Any letter font may be used for lettering.

2. Important Information:

It is important to have knowledge of the Elementary Geometry syllabus before attempting to solve the Intermediate Geometry syllabus.

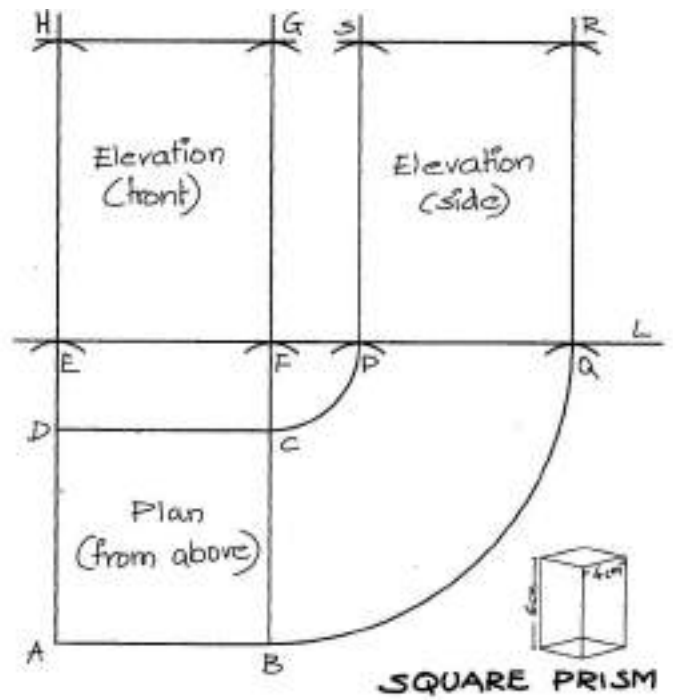
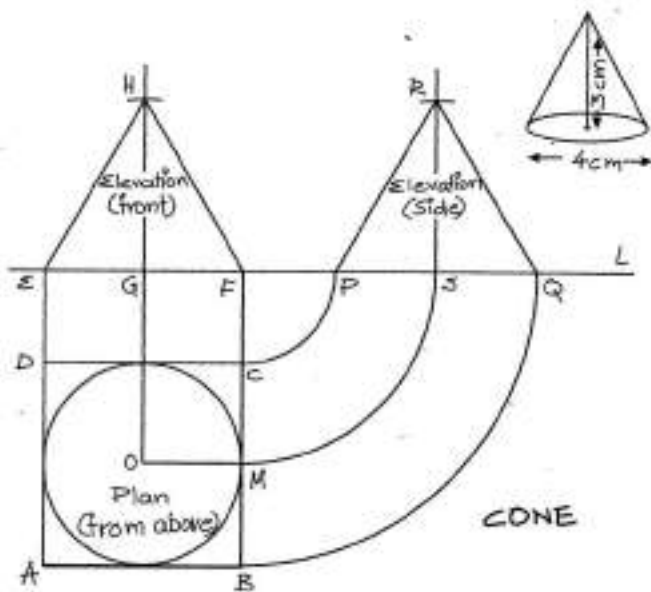
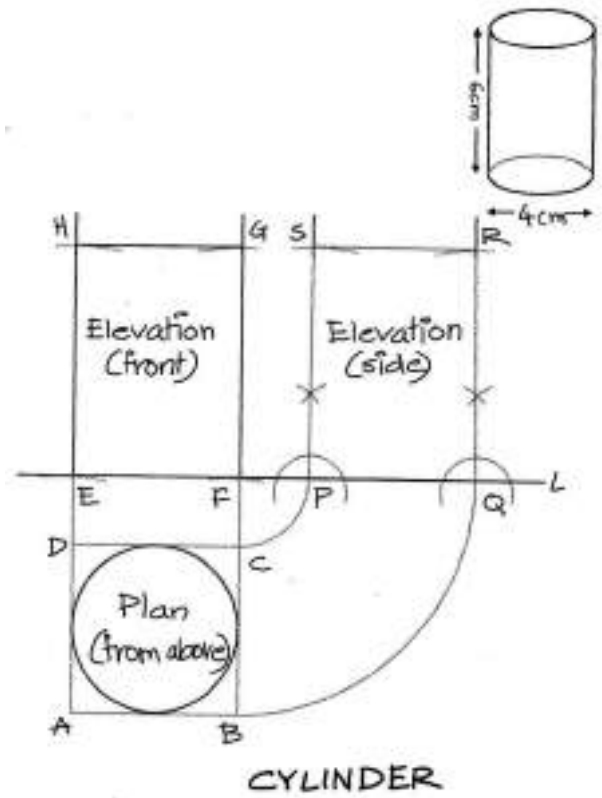
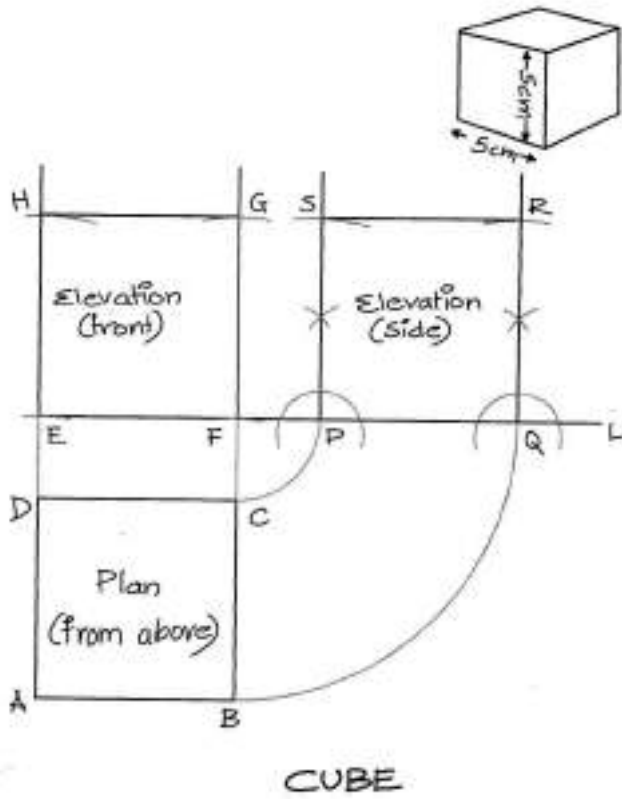

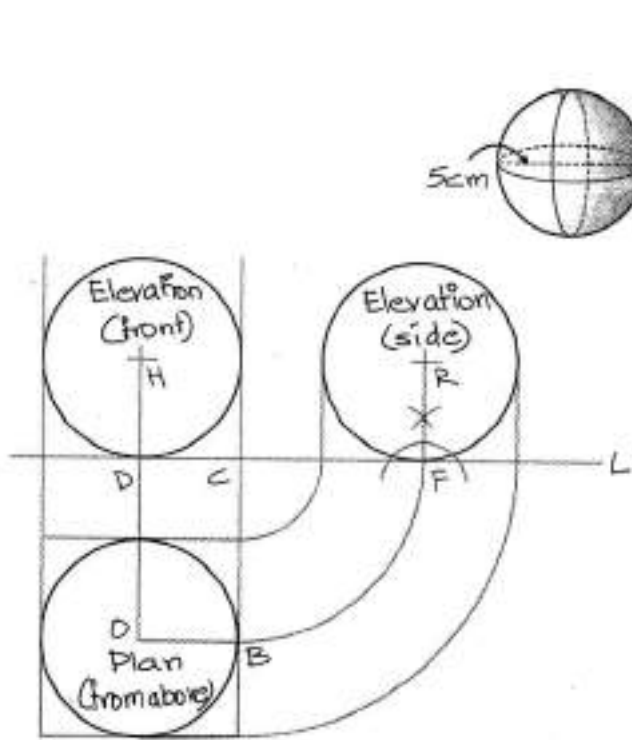

SPHERE

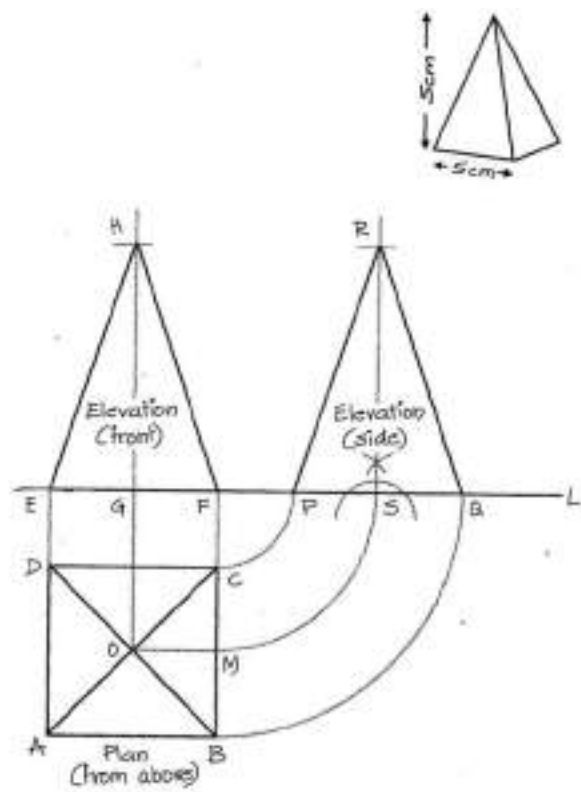

PYRAMID



Question paper
INTERMEDIATE GRADE EXAMINATION
PLANE GEOMETRY, SOLID GEOMETRY AND LETTERING
(Fourth Paper)
Total Time: 3 Hours]
(Second Day)
[Time: 2.30 pm to 5.30 pm]

Instructions for candidates:

(1) Solve any three questions from Section 'A' (Plane Geometry). (2) It is compulsory to solve all the questions in Section (Solid Geometry and Lettering). (3) All the lines drawn for the construction should be permanent. They should not be erased. (4) Give special attention to neatness and accuracy. (5) Use both sides of the paper if necessary.

For Geometry: Pencil or Pen.

For Lettering: Colour medium of your choice.

Tools: Mechanical instruments of Geometry Box.

Question Paper (2015):

SECTION 'A' (PLANE GEOMETRY)

Solve any three questions from Section 'A':

1. Draw a right angle triangle having hypotenuse $PQ = 8.5$ cm. and side $PR = 5$ cm.
2. Draw a circle passing through LMN points which are not in a straight line. (LMN points are non-collinear points)
3. Draw a square ABCD having sides 8cm. Inside this square, draw four equal circles in such a way that every circle should touch two sides of the square and the next two circles should touch the circumference of the remaining two circles.
4. Draw kite shape having adjacent sides $PQ = 4$ cm. and $QR = 8$ cm. and $\angle PQR = 110^\circ$.
5. $\angle ABC = 40^\circ$. Draw a circle of 2 cms. radius touching the two lines of the angle.

SECTION 'C' (SOLID GEOMETRY AND LETTERING)

Solve all the questions:

1. Draw the Plan and Elevation of a pyramid whose base = 4 cms. and height = 8 cms.
2. Draw a rectangle shaped board of size 20 x 8 cms.
3. In the above rectangle shaped board, make use of Roman/Devnagari or any Indian script for the lettering suitable to the meaning of the word/title given below. Colour it with colours of your choice.

'DNYANDEEP'